

Rep	REFERENCE	DESIGNATION	DESCRIPTION	Qte
1	PF 0120 1002	MANCHON DE SERRAGE	TOP SCREW	1
2	PL 0120 PM-4004-3 IND A	TOP SELF POWER 110	TOP CAP POWER 110	1
3	MP 0120 SM-0004 IND A	VIS TCHC TETE BASSE M4x25	SCREW CHC LOW HEAD M4x25	3
4	MP 0120 SM-0003 IND A	RONDELLE M4	WASHER M4	3
5	PL 0120 PM-4002 IND A	RESSORT SELF 40	SELF TAILING 40 SPRING	3
6	PL 0120 PP-4002 IND C	SELF HAUT	UPPER SELF JAW	1
7	PL 0120 PP-4001 IND C	SELF BAS	LOWER SELF JAW	1
8	PF 0120 4002 IND A	KIT SELF TAILING	SELF TAILING KIT	1
9	MP 0120 SM-0017 IND B	VIS CS M4x10 UNI6107	SCREW M4x10 SLOTTED CHEESE HEAD	6
10	PF 0120 AE-0006 IND A	NEZ EQUIPE 40	EQUIPED 40 NOSE	1
11	PL 0120 PM-0006 IND H	PUITS DE MANIVELLE	HANDLE SOCKET	1
12	PL 0120 1006	KIT MODULE POWER	MODULE POWER KIT	1
13	PL 0120 PM-0018 IND B	AXE PLANETAIRE R Z11	PLANETARY SHAFT R Z11	1
14	PF 0120 AE-6475 IND C	CAGE A AIGUILLES SUPERIEURE	TOP NEEDLE BEARING	2
15	PL 0120 PP-0012 IND A	ENTRETOISE CAGE	CAGE SPACER	1
16	PF 0120 AE-4003 INDC	CAGE A AIGUILLES BASSE	LOWER NEEDLE BEARING	1
17	MP 0120 SM-0019 IND A	Vis CHC M6x30	SCREW CHC M6X30	4
18	PL 0120 PP-0002 IND D	BAGUE COURONNE	CROWN RING	1
19	PL 0120 PM-0010 IND D	AXE CENTRAL	MAIN SHAFT	1
20	PL 0120 PM-4024 IND C	PIGNON Z24	PINION Z24	1
21	PF 0120 4003 IND A	KIT PIGNON DE SORTIE Z11	OUTPUT PINION Z11 KIT	1
22	PF 0120 1001	KIT CLIQUETS ET RESSORTS	PAWLS AND SPRINGS KIT	1
23	PL 0120 PM-4019 IND B	PIGNON Z19	PINION Z19	1
24	PL 0120 PM-4012 IND F	PIGNON Z12	Pinion Z12	1
25	PL 0120 PM-0014 IND D	AXE PIGNON SORTIE	Out put gear pin	1
26	PL 0120 SM-0028 IND A	VIS FF M2,5x8 UNI 6109	COUNTERSUNK HEAD SCREW M2,5x8	1
27	PL 0120 PP-4013 IND A	RONDELLE D'APPUI SMALL	SUPPORT WASHER SMALL	1
28	PF 0120 4004	KIT PIGNON INVERSEUR Z20	REVERSE PINION Z20 KIT	1
29	PF 0120 4017 IND A	EMBASE EQUIPEE 40-110	EQUIPED BASE 40-110 KIT	1

# Winch POWER110

Numéro de série depuis  
*Serial Numbers from*  
195-20 001



N° de série  
*Serial number*

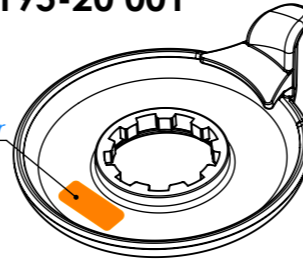

Rep	REFERENCE	DESIGNATION	DESCRIPTION	Qte
50	MP 0120 SP-0040 IND A	BAGUE ETANCHEITE TC Ø44XØ54X7	ROTARY SHAFT SEAL TCØ44XØ54X7	1
51	PL 0120 PM-4006 IND J	POUPEE 40-110	DRUM 40-110	1
52	PF 0120 1008	KIT RONDELLE APPUIS	THRUST WASHER KIT	1
53	PL 0120 PM-0041 IND A	RESSORT BAGUE DECLENCHEUR	TRIGGER RING SPRING	3
54	PL 0120 PP-0013 IND B	BAGUE DECLENCHEUR	TRIGGER RING	1
55	PL 0120 PP-0014 IND A	CARRE	TRIGGER BLOCK	3
56	MP 0120 SM-0022 IND A	VIS CHC Tete Basse M3x8 UNI 9327	SCREW CHC LOW HEAD M3x8	3
57	PL 0120 PP-4007 IND A	PLATINE COURONNE	CROWN PLATE	1
58	PL 0120 PM-4047 IND A	COURONNE 40-110	CROWN 40-110	1
59	MP 180 5917	VIS TCHC M3X6 INOX A4	SCREW CHC M3X6 INOX A4	3
60	PF 0120 4008	KIT COURONNE 40-110	CROWN 40-110 kit	1
61	PL 0120 PP-4010 IND B	PATIN	FRICITION PAD	4
62	PL 0120 PM-0046 IND A	RESSORT POWER STRONG	POWER STRONG SPRING	2
63	PL 0120 PP-4009 IND B	RONDELLE POUPEE	DRUM WASHER COVER	1
64	MP 0120 SM-0018 IND B	VIS CS M3X12 UNI6107	SCREW M3x12 SLOTTED CHEESE HEAD	4

Rep	REFERENCE	DESIGNATION	DESCRIPTION	Qte
40	PF 0120 4019 IND A	KIT BATI POWER	POWER FRAME KIT	1
41	PF 0120 AE-0001 IND B	EMBRAYAGE	CLUTCH	1
42	PF 0120 1007	KIT BAGUE D'ARRET	STOP RING KIT	1
43	MP 0120 SM-0017 IND B	Vis CS M4x10 UNI6107	SCREW CS M4x10 UNI6107	3

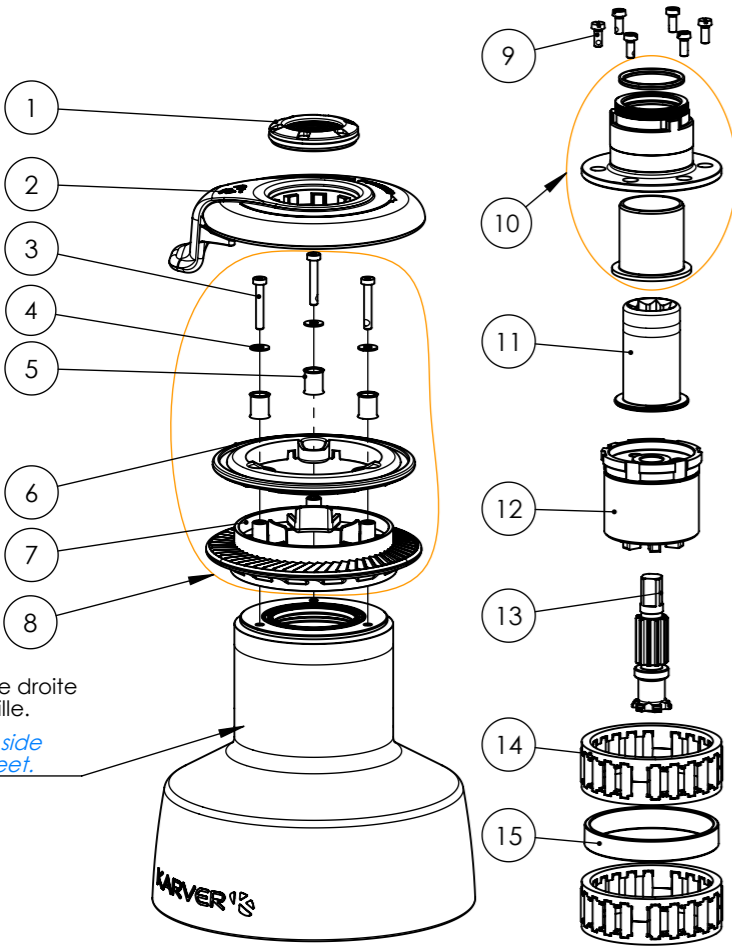
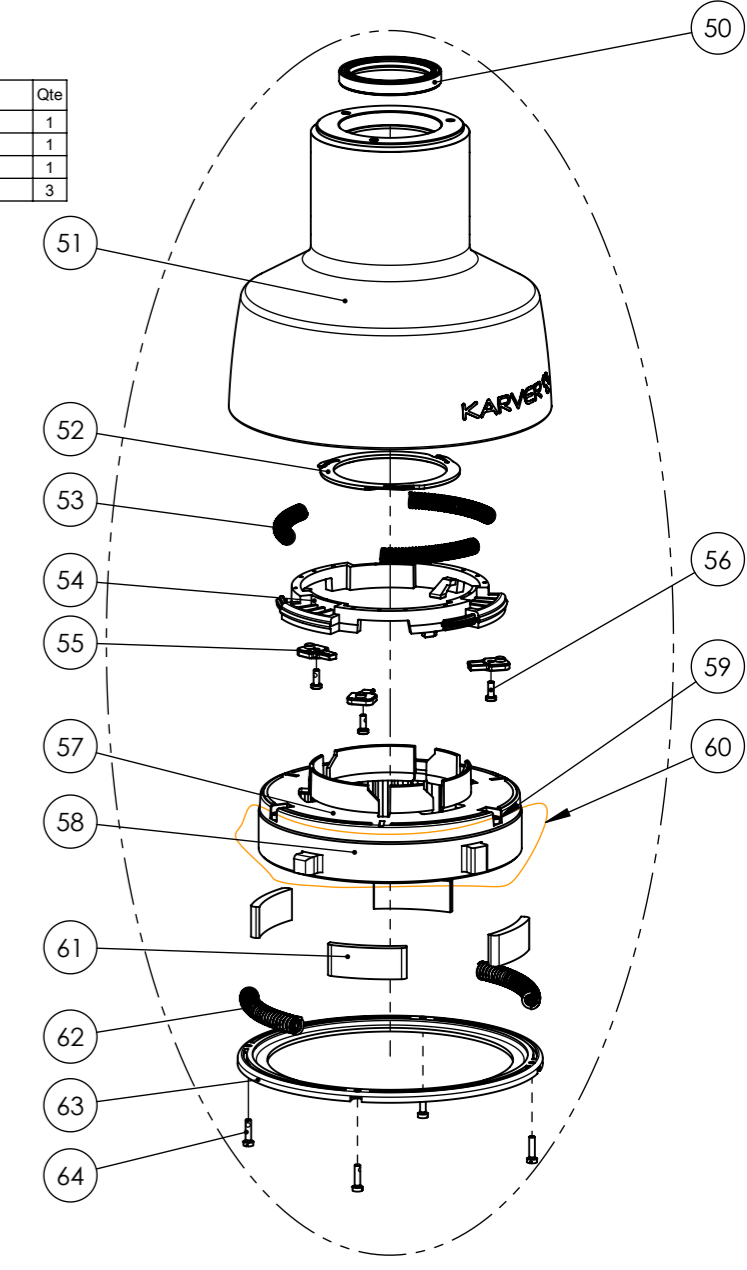
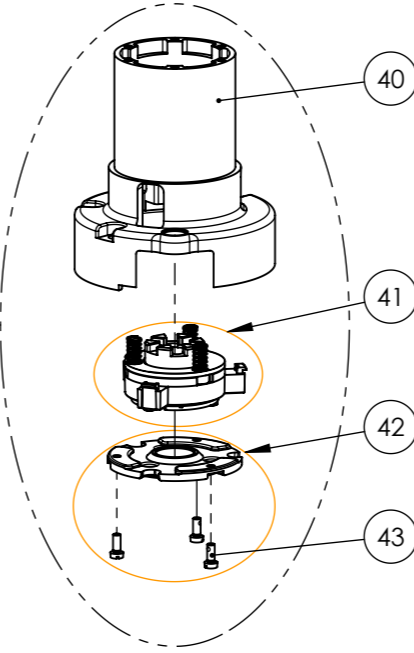
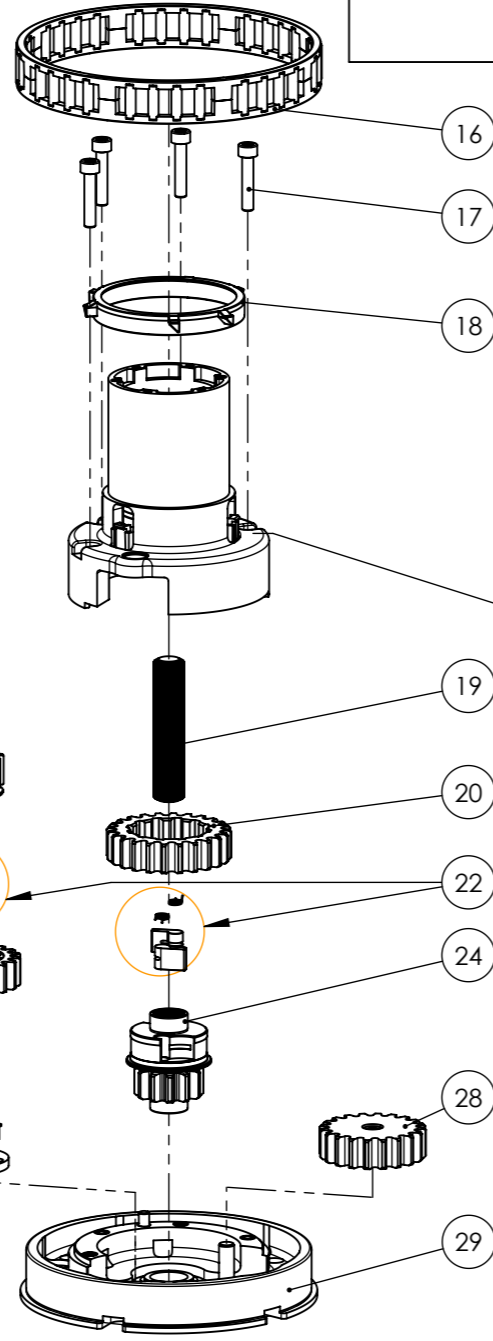

Voir partie droite de la feuille.  
*See right side of the sheet.*

07/05/2019	Création du plan	XD	MC	A
Date	MODIFICATIONS APORTEES	Nom	VISA	IND.