

DRILL 2 X 12.5MM HOLES ON 32.0MM CENTRES

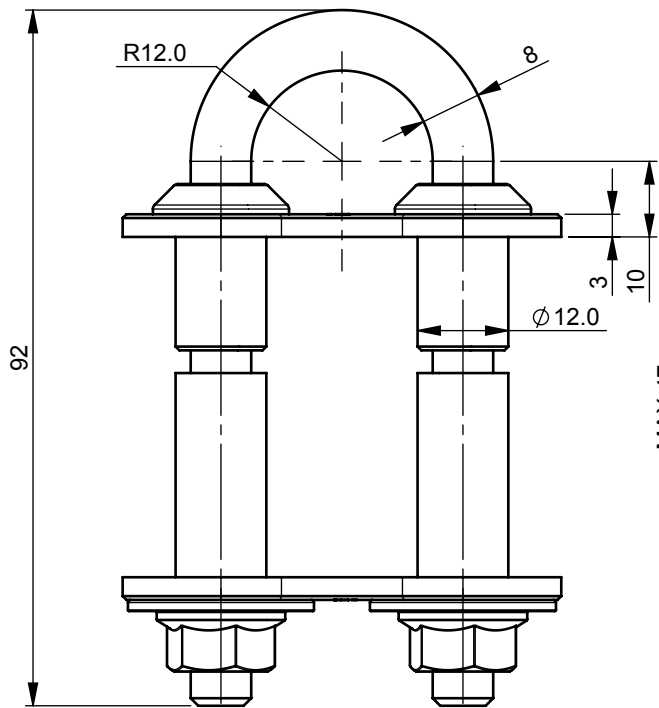

MAX 47
MIN 13
DECK
THICKNESS

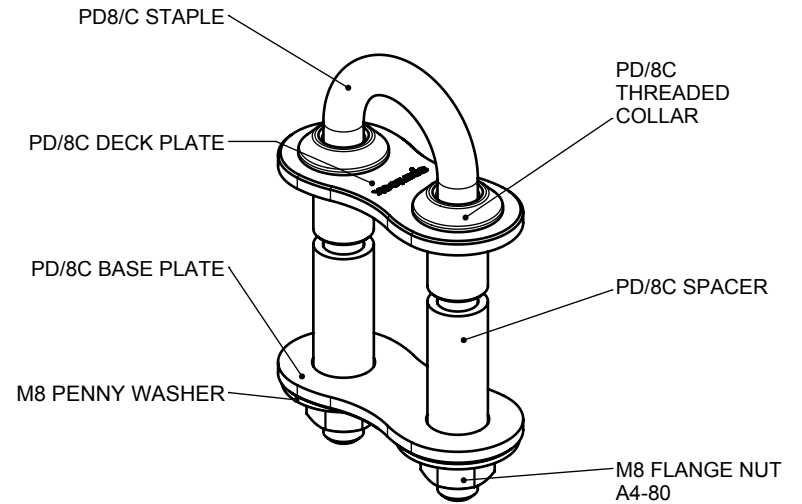
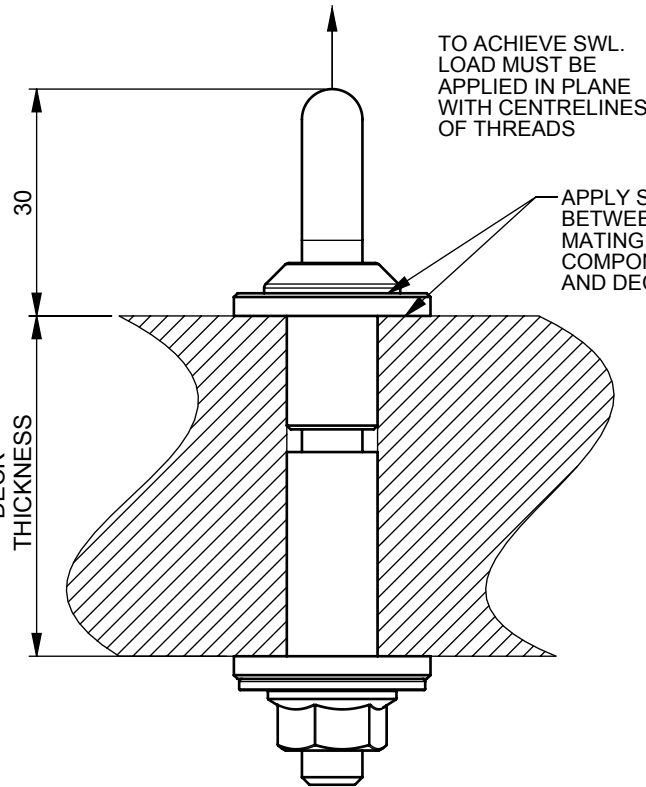

TO ACHIEVE SWL. LOAD MUST BE APPLIED IN PLANE WITH CENTRELINES OF THREADS

APPLY SEALANT BETWEEN MATING COMPONENTS AND DECK

IMPORTANT:

ENSURE PLASTIC SPACERS PROTRUDE THROUGH UNDERSIDE OF DECK AND INTO BASE PLATE HOLES. IF REQUIRED, CUT PLASTIC SPACERS TO LENGTH.

SPACER LENGTH = DECK THICKNESS - 13MM

FOR DECKS LESS THAN 15MM THICK, DO NOT USE SPACER TUBES.

ENSURE STAPLE HEIGHT DOES NOT EXCEED 30MM ABOVE DECK.
ENSURE DECK PLATE SITS PERPENDICULAR TO STAPLE AXES.

DO NOT OVERTIGHTEN NUTS, MAX TORQUE = 17Nm

APPLY SEALANT/JOINTING COMPOUND BETWEEN THREADED COLLAR, DECK PLATE AND AND STAPLE.

spinlock
BE ADVENTURE-PROOF



WARNING:
IF USING AS TEMPLATE, ENSURE PRINTER SETTINGS ARE ADJUSTED TO ACCOUNT FOR THE DRAWING SCALE AND **ALWAYS** CHECK DIMENSIONS.



COPYRIGHT:
THIS DRAWING IS PROTECTED BY COPYRIGHT. ANY USE IS FORBIDDEN WITHOUT THE WRITTEN CONSENT OF SPINLOCK.

ALL DIMENSIONS IN MM

FASTENERS

WEIGHT

MAX LOAD

SCALE PAGE SIZE DATE

M8 x 2

145g

0° FROM VERTICAL, SWL = 4000KG
45° FROM VERTICAL, SWL = 2400KG
90° FROM VERTICAL, SWL = 2400KG

1:1 A4

APR 2018

PD/8C

FOR MORE INFO CONTACT
SPT@SPINLOCK.CO.UK